



DATACENTRE



TRANSPORT



E-MEDICAL



INDUSTRY

# Multi Guard Industrial



ONLINE



Modular



Service 1st start



USB plug



SmartGrid ready



**1-3:1** 20 x 160 kVA

**1-3:3** 20 x 160 kVA

## HIGHLIGHTS

- **High adaptability to input voltage**
- **Zero impact source**
- **Compatible with industrial environments**
- **Modular Plug & Play solution**
- **Complete flexibility**

The Multi Guard Industrial range was specially developed to ensure power continuity in all sectors deemed critical due to the specific environmental conditions or industrial processes requiring protection.

Multi Guard Industrial is available in a 20 kVA standalone version and in modular versions from 20 to 160 kVA. The two versions are available in both single-phase and three-phase output configurations. This high level of flexibility allows Multi Guard Industrial to accept both single-phase and three-phase inputs with no need for special set ups or operator intervention, ensuring full compatibility with any power supply network.

### HIGH ADAPTABILITY TO INPUT VOLTAGE

Multi Guard Industrial is available in two versions: single-phase and three-phase output, whilst the input stage accepts both a triplet of three-phase supplies out-of-phase by 120° (three-phase 400 V+N) or a triplet of power supplies in phase (single-phase 230 V+N). Thanks to its power supply recognition function the UPS is able to adapt to the input power supply with no need for additional configuration, ensuring the same performance under both applied voltage conditions.

### ZERO IMPACT SOURCE

Thanks to the technology it employs, Multi Guard Industrial solves all problems





Parallel configuration and programmable relay contacts board.



Harting connectors.

connected with insertion into power supply grids with limited power, where the UPS is supplied by a generator and where the same network includes single-phase (e.g. railway voltage) and three-phase (e.g. emergency power supply from a generator) supplies.

Multi Guard Industrial has zero impact on the power supply source, whether it is a mains grid or generator set, single-phase or three-phase:

- Power supply voltage recognition (single/three-phase), with no need for setting up or reconfiguring parameters;
- Input current distortion <3%;
- Input power factor 0.99;
- Power walk-in function that ensures progressive rectifier start up;
- Start up delay function, to restart the rectifiers when mains power is restored if there are several UPS in the system;
- 'Cold start' function for starting the UPS from the battery.

In addition, Multi Guard Industrial plays a filtering and power factor correction role in the power network upstream of the UPS as it eliminates harmonic components and reactive power generated by utility suppliers.

### COMPATIBLE WITH INDUSTRIAL ENVIRONMENTS

The mechanical structure of Multi Guard Industrial makes it particularly versatile for use in many different sectors.

The basic building blocks are 20 kVA UPS. The cabinet is able to house up to four 20 kVA modules and up to two cabinets can be connected in parallel for a total of eight UPS modules and 160 kVA of power.

The module connection clamps are laid out so that the communication signal connections are segregated and separated from the power connections (input, output, bypass line, battery), thus ensuring complete immunity from interference generated by the power supply grid, which is typically disturbed in industrial environments.

Both versions (single-phase and three-phase output) are provided with a bypass line separated from the power supply line. This ensures greater availability in that the customer may have a preferential line for the bypass that is not restricted by the potential interference or interruptions that the UPS power supply line may be subject to. The UPS module has a front to back air flow, allowing the UPS to be installed in any environment and preventing the types of ingress problems associated with top-vented circulations cabinets.

Every UPS module in the Multi Guard Industrial range can be equipped with a parallel board, a relay board with eight programmable outputs and three inputs (one of which is programmable), and two slots for housing communications interface boards from the MultiCom range, making the UPS compatible with the various types of protocols and supervision systems typical of the industrial environment.

The cabinet is designed to house up to four UPS modules. It has an area that contains all the protection devices and disconnectors for the individual modules (4 input disconnectors, 4 battery disconnectors, 4 bypass line disconnectors and 4 output

disconnectors), as well as a manual bypass for isolating the four modules and guaranteeing power continuity in the event of the complete failure of all the UPS units or in the event of scheduled system overhaul.

The cabinet is also equipped with an area that can be used for the insertion of a whole range of accessories for monitoring power that the user can request (surge arresters, energy meters, earth discharge detectors, output distribution, release coils, etc), making the solution compact and optimised for any field of use.

### MODULAR PLUG & PLAY SOLUTION

Multi Guard Industrial can be purchased as a single 20 kVA UPS module and installed in any cabinet or mechanical support provided by the user. The power terminals (input, output, battery) are connected by harting connectors, ensuring simplicity and operating safety during insertion/removal, protection against electrical contacts and immunity from environmental conditions typical of industrial environments (dust, humidity, suspended chemical particles). The removal and replacement of a faulty module or the addition into the system of a further UPS module to increase available power or redundancy can be carried out easily by the operator responsible for the system.

### COMPLETE FLEXIBILITY

Multi Guard Industrial is the ideal solution for industrial environments in which the UPS must adapt to the various

requirements typical of this application. Aside from the distinction between single-phase and three-phase output voltages, the UPS module can be used as a standalone unit or in a parallel configuration; by simply adding the parallel configuration board in the slot on the front of the module, the UPS can grow as requirements demand (from 20 to 160 kVA). Multi Guard Industrial ensures horizontal scalability that minimises the system footprint, the user can thus have power capabilities from 20 to 80 kVA without increasing the footprint. This is particularly advantageous when the system is installed in environments with space limitations (e.g. containers, historic buildings, sites spread out over a territory). Each UPS is equipped with a graphic display, a programmable relay board slot and two slots for communications interfaces, all situated at the front for quick and organised installation. Every UPS module in the Multi Guard Industrial range is completely independent with regards to the control and management of the operator interfaces; this facilitates all monitoring, control and fault-detection operations,

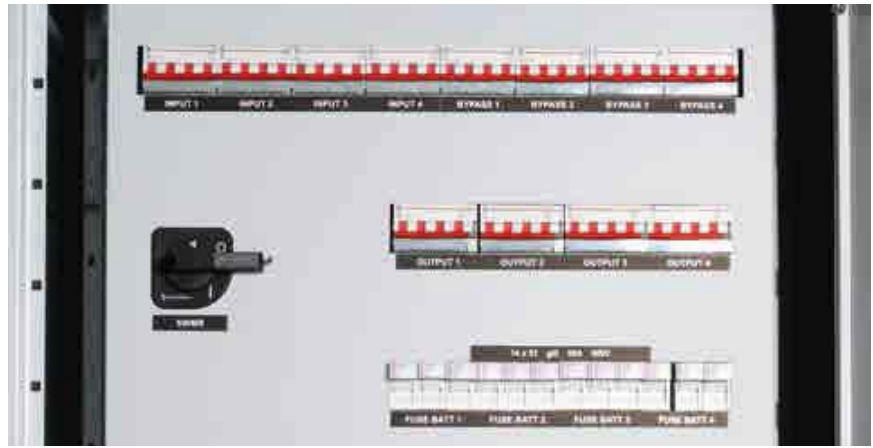

Detail of protective devices and disconnectors.

ensuring increased reliability in that any malfunctions in parts or accessory will not propagate through the entire system. Multi Guard Industrial is a UPS that uses many components also used in the Multi Sentry range; in particular the display and navigation menus are the same: this allows for rapid and intuitive access to information as well as simplified management of the spare parts in storage.

### STANDALONE VERSION:

Different from the cabinet version, the standalone system is supplied with input, bypass line, output and battery connectors with loose cables three metres in length and filter boards that the installation technician must position inside the destination cabinet or near the module.

## OPTIONS

SOFTWARE
PowerShield <sup>3</sup>
PowerNetGuard
ACCESSORIES
NETMAN 204
MULTICOM 302
MULTICOM 352
MULTICOM 384
MULTICOM 411
MULTI I/O
MULTIPANEL

PRODUCT ACCESSORIES
Battery temperature sensor
Powerful battery charger
Programmable relay board
Multicom 392
IP rating IP31/IP42
Internal batteries
MST range battery cabinets

## DETAILS

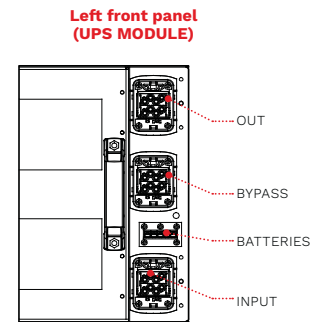
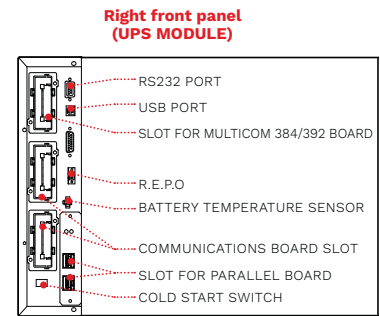

<b>MODEL</b>	<b>GMI single-phase output (GMI M) from 20 kVA to 160 kVA</b>	<b>GMI three-phase output (GMI T) from 20 kVA to 160 kVA</b>
<b>INPUT</b>		
Rated voltage [V]	380 / 400 / 415, three-phase + N and 220 / 230 / 240 single-phase + N (input voltage recognition function)	
Voltage tolerance [V]	230 / 400 ±20% @ full load <sup>1</sup>	
Frequency tolerance [Hz]	40-72	
Power factor	>0.99	
THDI	<3%	
<b>BYPASS</b>		
Rated voltage [V]	220 / 230 / 240, single-phase + N	380 / 400 / 415, three-phase + N
Voltage tolerance [V]	180 / 264 (selectable) referring to neutral phase	
Rated frequency [Hz]	50 or 60	
Frequency tolerance [Hz]	±5% (selectable)	
Overload	125% for 60 min.; 150% for 18 min.	
<b>OUTPUT</b>		
Voltage [V]	220 / 230 / 240, single-phase + N (selectable)	380 / 400 / 415, three-phase + N (selectable)
Voltage stability	≤1%	
Frequency [Hz]	50 / 60	
<b>UPS MODULE</b>		
Power [kVA/kW]	20 / 18	
Output power [kVA]	20 x number of modules, up to a maximum of 8 (max. 160)	
<b>BATTERIES</b>		
Layout	independent batteries for each UPS module or shared by the UPS system	
Type	VRLA AGM/GEL	
Recharge time	6 h	
<b>OVERALL SPECIFICATIONS</b>		
Noise level at 1 m (ECO Mode) [dBA]	from ≤52 to ≤70	
Ambient temperature for the UPS	0 °C - +40 °C	
Range of relative humidity	20% - 90% non-condensing	
Storage temperature	-15 °C +55 °C	
UPS module weight [kg]	64	
UPS module dimensions (WxDxH) [mm]	620x745x320	
GMI cabinet weight [kg]	200 (UPS modules excluded)	
GMI cabinet dimensions (WxDxH) [mm]	850x850x2060	
Modular battery cabinet dimensions (WxDxH) [mm]	9 battery shelves, 36 battery modules 597x1003x2000	
ECO Mode efficiency	up to 99%	
Standards	European directives: L V 2014/35/EU low voltage Directive EMC 2014/30/EU electromagnetic compatibility Directive Standards: Safety IEC EN 62040-1; EMC IEC EN 62040-2; RoHS compliant Classification in accordance with IEC 62040-3 (Voltage frequency Independent) VFI - SS - 111	
Moving the UPS	Pallet jack (UPS cabinet) - 2 operators (UPS module)	

<sup>1</sup> For wider tolerance conditions apply.

NOTE: The GMI UPS is also compatible with the battery cabinets in the Multi Sentry range (MST)