

Master HP & Master HE



DATACENTER



E-MEDICAL



EMERGENCY



INDUSTRY



TRANSPORT

3:3 Master HP 100-600 kVA
Master HE 100-800 kVA



ONLINE



Tower



Lithium compatible



Service 1st start



SmartGrid ready



Supercaps UPS



HIGHLIGHTS

Best in class efficiency

The Master HP and Master HE series represent the optimum Riello UPS solution for installations requiring high efficiency, a low impact on the mains and maximum power availability.

as the Master HP. The use of IGBTs for both the rectifier and inverter stages reduces any switching losses, ensuring nominal power with no downgrading up to 40 °C.

IGBT rectifier

Their ON LINE technology (classified as VFI-SS-III) combined with the transformer-based design and IGBT rectifier provide not only maximum protection and power quality to the most critical applications such as data centers or industrial loads, but also minimises the impact on the mains supply and reduces the risk of oversizing generator sets.

The DSP (Digital Signal Processor) control allows the use of more complex and high performance algorithms that guarantee better static and dynamic performance. Moreover, the firmware and main components of the Master HE are specifically designed to ensure the best in class efficiency of 95.5% in ON LINE Mode and unity output power factor (kW=kVA), which means 11% higher active power than a comparable UPS with 0.9 output power factor.

MASTER HE - HIGH EFFICIENCY

Available from 100 to 800 kVA, the Master HE series shares the same consolidated and reliable double conversion technology



MAXIMISED COST SAVINGS

Master HP/HE supports the SMART ACTIVE Mode, meaning they are capable of selecting the best operating mode between ON LINE or ECO depending on the quality of the mains, maximising UPS efficiency.

Master HP/HE also guarantees high efficiency at partial loads and in case of parallel installations, the units can work in EFFICIENCY CONTROL Mode (ECM) to increase efficiency whilst still ensuring the required redundancy: depending on the real-time load, it sets surplus UPS units to "idle", allowing the live units to run at the most efficient working point. ECM implements also a smart logic to ensure the units and components age at a similar rate.

POWER CONTINUITY

For years, Riello UPS has developed and supplied solutions for dealing with the different requirements and problems that inevitably arise in critical applications. Riello UPS offers flexible, high-availability solutions that are able to adapt to different system structures and critical levels. Riello UPS creates UPS systems that can tolerate a number of components or subsystem failures, while continuing to operate normally, providing power without interruption.

This is achieved by careful design, installing redundant elements, eliminating common failure points, scheduling maintenance activities and controlling and supervising the system operating parameters and environment. The TEC service team is ready to provide guidance and advice on projects.

ZERO IMPACT SOURCE

The Master HP/HE series features the added advantages of the Zero Impact Source formula offered by an IGBT-based rectifier assembly. This eliminates problems connected with installation in networks with limited power capacity, where the UPS is supplied by a generator set, or anywhere there are compatibility problems with loads generate current harmonics. Master HP/HE series UPS have zero impact on the power supply source, whether it is a mains grid or generator set:

- input current distortion <3%;
- input power factor 0.99;
- power walk-in function that ensures progressive rectifier start up;
- start up delay function, to restart the rectifiers when mains power is restored if there are several UPS in the system.



BATTERY CARE SYSTEM

The Master HP/HE series of UPS include a range of features designed to prolong battery life and reduce their usage such as different recharging methods, deep discharge protection, current limitation and voltage compensation according to the battery room temperature. Thanks to the STEP-UP/STEP-DOWN converter that recharges and discharges the battery, ripple current is extremely reduced; this arrangement enhances the battery reliability since it is no longer connected to UPS DC bus.

COMPLETE GALVANIC SEPARATION

Master HP/HE UPS features an output isolation transformer (delta zig/zag type) on the inverter as part of the inverter circuit inside the UPS cabinet, providing galvanic isolation between the load and the battery with improved versatility in system configuration, allowing:

- Complete UPS output galvanic isolation for critical infrastructures from the battery DC power source;
- Two truly separated supply inputs (main and bypass), which can be taken from two different power sources (with different neutrals); this is particularly well suited to parallel systems in order to ensure selectivity between the two sources, thus improving the reliability of the entire installation;
- No neutral input connection is required at the UPS rectifier input stage; this method is particularly favourable in order to prevent the transmission of common

neutral disturbances via the neutral conductor;

- No effects to the UPS output performance or reduced impact of the inverter power components whilst supplying specific loads; in addition the inverter transformer minimises the impact of third harmonic disturbances.
- High inverter short circuit current to clear faults which occur between phase and neutral on load side (up to three times nominal current).
- Output transformer housed within the cabinet which allows for a significant reduction in the footprint and provides space saving.

MAIN FEATURES

- High efficiency up to 99.4% (STANDBY ON Mode);
- Compact size: e.g. only 0.85 m² for the Master HP/HE 250 kVA;
- Reduced weight for transformer-based UPS;
- Double load protection, both electronic and galvanic, towards the battery.

The entire Master HP/HE range is suitable for use in a wide range of applications. Thanks to the flexibility of configuration, available options and accessories, it is suitable for supplying any type of load, e.g. capacitive loads such as blade servers, rather than motor drivers or any other critical vertical application.

SMART GRID READY

Being Smart Grid Ready, Master HP/HE allows for the implementation of energy

storage solutions and at the same time ensures extremely high levels of efficiency. It is also able to independently select the most efficient operating method based on the status of the grid. Master HP/HE UP can electronically interface with the ENERGYMANAGER using the smart grid communication network.

MAXIMUM RELIABILITY AND AVAILABILITY

- Distributed parallel configuration of up to 8 units per redundant (N+1) or power parallel system;
- Centralised parallel system up to 7 units with centralised bypass system (MSB);
- Dual bus configuration: allows two or more non-parallel UPS devices to remain synchronised even during mains power failure by adding the UGS device. The UGS also enables a Riello UPS to be synchronised with another power source that is independent and of a different power rating;
- Dynamic Dual bus configuration: allows two groups of UPS with the PSJ device to be connected in parallel whilst operating, in the event of maintenance (with no interruption to the output), using a power coupling switch. Should one of the UPS in one of the parallel groups fail, it is automatically excluded. The PSJ connects the remaining UPS, to the other parallel group via an external bypass, in order to continue to guarantee load redundancy. Allows two groups of UPS to be connected in parallel whilst operating, in the event of maintenance (with no interruption to the output), using a power coupling switch. Should one of the UPS in one of the parallel groups fail, it is automatically excluded.
- Hot System Expansion (HSE): allows the addition of a further UPS into an existing system, without the need to switch off the existing UPS or switch to bypass. This guarantees maximum load protection, even during maintenance and system expansion;
- Maximum levels of availability, even in the event of an interruption to the parallel bus cable: the system is "FAULT TOLERANT". It is not affected by connection cable faults and continues powering the load without disruption, signalling an alarm condition;
- EFFICIENCY CONTROL Mode (ECM): it optimises the operating efficiency of parallel systems, according to the power required by the load. N+1 redundancy is guaranteed, with every UPS working in parallel at the best load level possible to achieve higher overall efficiency.

CENTRALISED BYPASS CABINET

The Riello UPS centralised bypass (named MSB) is available in five power ratings: 800, 1200, 1600, 2000 and 3000 kVA.

Intermediate solutions within this range can be made, as well as solutions greater than 3000 kVA based on the requirements of the customer or application. The MSB centralised bypass can be integrated with the Master HP/HE range; in fact it can be associated with up to 7 UPS modules in the range, obviously without static bypass and associated bypass line (named MHT/MHE NBP). Based on requirements thus ensuring complete flexibility aimed at satisfying all power and power supply requirements.

Riello UPS provides the same flexibility as the Master HP for the battery bus, so that the UPS units can operate with both shared and separate batteries.

The 800 kVA MSB is supplied with a comprehensive cabinet including bypass

line input switch (SWBY), system output switch (SWOUT) and manual bypass (SWMB). The 1200 and 1600 kVA models are supplied as standard without any switches but can be equipped with the same, suitably proportioned, switches provided for the 800 kVA model (SWBY, SWOUT, SWMB).

The more powerful models are supplied with no switches; the bulky sizes of disconnection devices at these power levels are such as to favour tailor-made engineering solutions as an additional part of the system attestation and distribution cabinets where the centralised bypass and MHT/MHE NBP modules are fitted.



Master Static Bypass MSB



PARALLEL CONFIGURATION OF UP TO 8 UPS UNITS WITH DISTRIBUTED BYPASS

Parallel architecture to ensure redundancy of the power source.

+ Flexibility and modularity and no single point of failure.

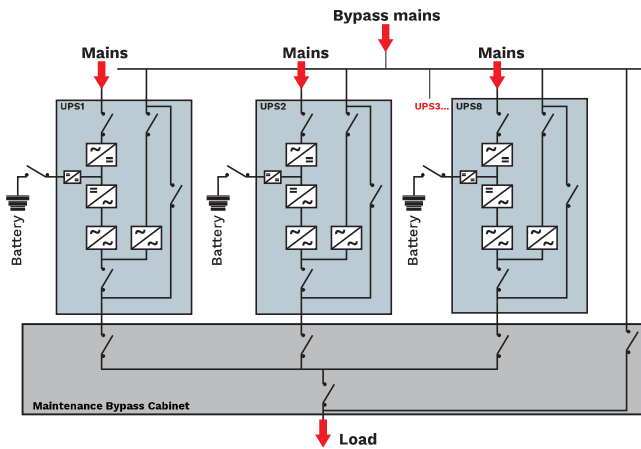

PARALLEL CONFIGURATION OF UP TO 7 UNITS WITH CENTRALISED BYPASS

Parallel architecture to ensure redundancy of the power source, with independent bypass management.

+ Selectivity of downstream faults in bypass operation

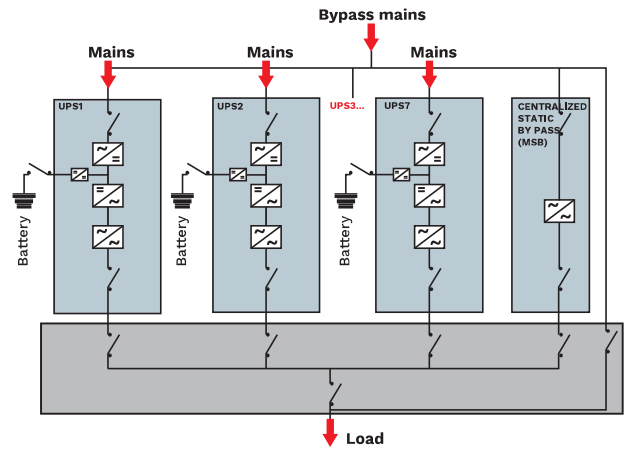

DUAL BUS CONFIGURATION

Solution to ensure redundancy through synchronization of two power buses and improving STS operation.

+ Downstream fault discrimination

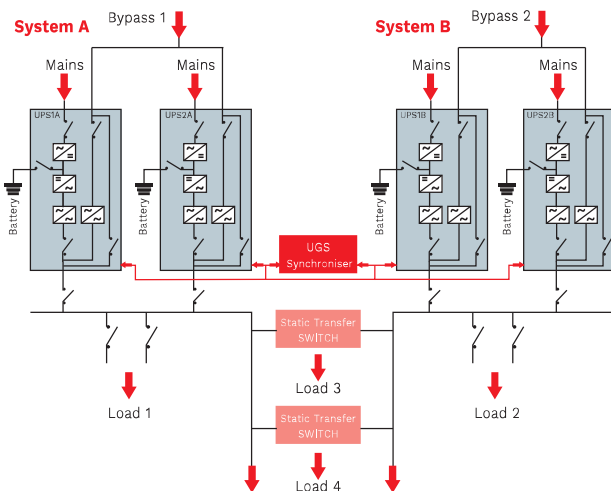

DYNAMIC DUAL BUS CONFIGURATION

Solution to ensure redundancy of the power supply even during maintenance.

+ High availability and redundancy

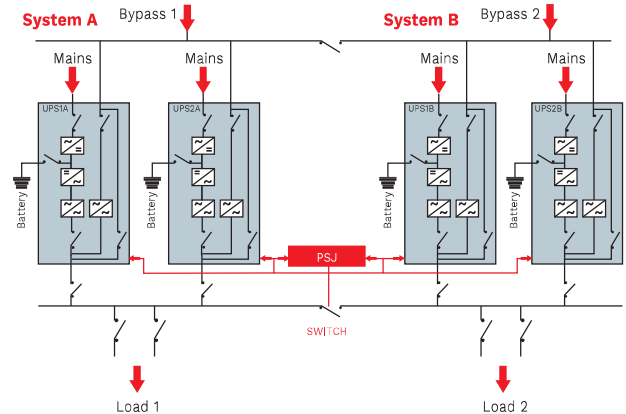

OPTIONS

SOFTWARE

PowerShield³
PowerNetGuard

ACCESSORIES

NETMAN 208
MULTICOM 302
MULTICOM 352
MULTICOM 411
MULTICOM 421
MULTI I/O
MULTIPANEL
MBB 400 A 4P

PRODUCT ACCESSORIES

Bypass isolation transformer
Parallel kit
Synchronisation device (UGS)
Hot connection device (PSJ)
Top Cable Entry cabinet
IP rating IP21, IP31/IP42 on request
Battery temperature sensor
Cold start
ENERGYMANAGER
DC filter
Power Absorber (PWA)

DIMENSIONS

MHT / MHE 100
MHT / MHE 120

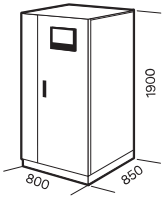

MHT / MHE 160
MHT / MHE 200
MHT / MHE 250

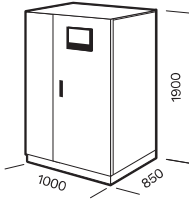

MHT / MHE 300
MHT / MHE 400

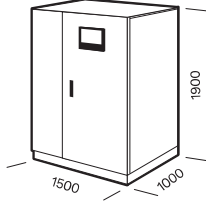

MHT / MHE 500
MHT / MHE 600

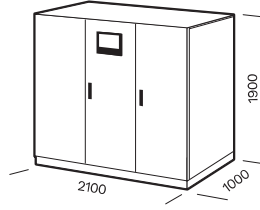

MHE 800

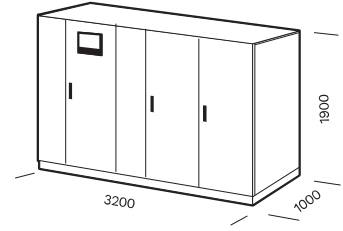

MSB 800

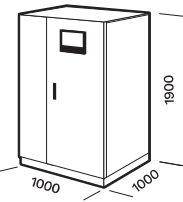

MSB 1200

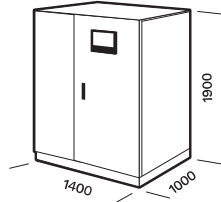

MSB 1600 / MSB 2000

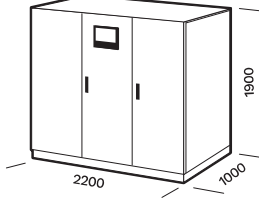

MSB 3000

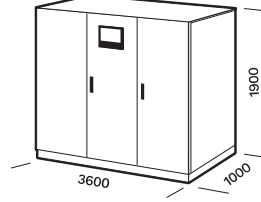

BATTERY CABINET

MODELS

BTC 1900 480V BB V6 3T
BTC 1900 480V BB V7 3T
BTC 1900 480V BB V8 3T
BTC 1900 480V BB V9 3T
BTC 1900 480V AB V9 3T

UPS MODELS

MHT 100-600 / MHE 100-800

Dimensions
[mm]

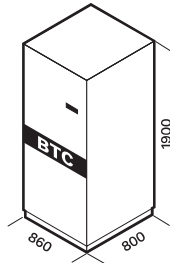

CABINETS WITH TOP ACCESS FOR CABLES

MODELS

MHT TCE 100÷250

MHT TCE 300÷800

UPS MODELS

MHT 100-250
MHE 100-250

MHT 300-600
MHE 300-800*

Dimensions
[mm]

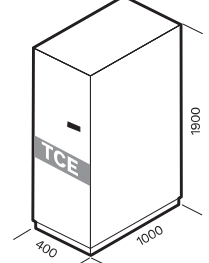
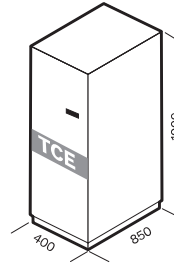

*2 pieces needed for MHE 800

THREE-PHASE ISOLATION TRANSFORMERS

MODELS

TBX ISO 100 T Dzn0
TBX ISO 160 T Dzn0

TBX ISO 200 T Dzn0
TBX ISO 250 T Dzn0

TBX ISO 300 T Dzn0
TBX ISO 600 T Dzn0

UPS MODELS

MHT 100-160 / MHE 100-160

MHT 200-250 / MHE 200-250

MHT 300-600 / MHE 300-600

Dimensions
[mm]

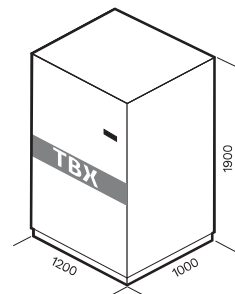
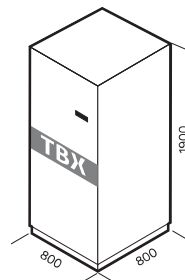
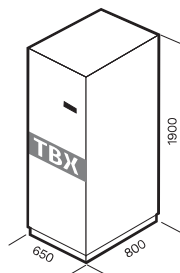

Note: TBX ISO 800 T Dzn0 for MHE 800 available on request.

MODELS	MHT 100	MHT 120	MHT 160	MHT 200	MHT 250	MHT 300	MHT 400	MHT 500	MHT 600	
INPUT										
Rated voltage [V]	380 / 400 / 415 three-phase									
Voltage tolerance [V]	400 ±20% @ full load ¹									
Frequency [Hz]	45 - 65									
Power factor	>0.99									
Harmonic current distortion [THDi]	<3%									
Soft start	0 - 100% in 120 s (selectable)									
BYPASS										
Rated voltage [V]	380 / 400 / 415 three-phase + N									
Rated Frequency [Hz]	50 or 60 (selectable)									
Frequency tolerance	±2% (selectable from ±1% to ±5%)									
Standard equipment provided	Backfeed protection; separable bypass line									
OUTPUT										
Nominal power [kVA]	100	120	160	200	250	300	400	500	600	
Active power [kW]	90	108	144	180	225	270	360	450	540	
Number of phases	3 + N									
Rated voltage [V]	380 ¹ / 400 / 415 three-phase + N (selectable)									
Static stability	±1%									
Dynamic stability	EN 62040-3 class performance 1 non-linear load									
Voltage distortion	<1% with linear load / <3% with non-linear load									
Crest factor [I _{peak} /I _{rms}]	3:1									
Frequency stability on battery	0.05%									
Frequency [Hz]	50 or 60 (selectable)									
Overload	110% for 60 min; 125% for 10 min; 150% for 1 min									
BATTERIES										
Type	VRLA AGM/GEL/NiCd/Li-ion/SuperCaps									
Recharging method	One level, Two level, Cyclic recharge (selectable)									
Battery arrangement (parallel systems)	Separate/Common									
OVERALL SPECIFICATIONS										
Weight [kg]	700	755	830	956	1060	1500	1720	2525	2700	
Dimensions (WxDxH) [mm]	800x850x1900		1000x850x1900			1500x1000x1900		2100x1000x1900		
Remote signals	1x opto insulated Input and 3x relays Outputs									
Auxiliary signals	R.E.P.O. - External manual bypass - External output switch									
Communications	UPS status LEDs - Graphic display - 2 slots for communications interface - 2x RS232									
Ambient temperature for the UPS	0 °C - +40 °C									
Recommended temperature for battery life	+20 °C - +25 °C									
Range of relative humidity	5-95% non-condensing									
Colour	RAL 7016									
Noise level at 1 m [dBA ±2] ECO Mode	65		68			72				
IP rating	IP20									
ECO Mode efficiency	up to 98%									
Standards	European directives: LV 2014/35/EU low voltage Directive EMC 2014/30/EU electromagnetic compatibility Directive Standards: Safety IEC EN 62040-1; EMC IEC EN 62040-2; RoHS compliant Classification in accordance with IEC 62040-3 (Voltage frequency Independent) VFI - SS - 111									
Moving the UPS	Pallet jack									

¹ For wider tolerance conditions apply.

MODELS	MHE 100	MHE 120	MHE 160	MHE 200	MHE 250	MHE 300	MHE 400	MHE 500	MHE 600	MHE 800
INPUT										
Rated voltage [V]	380 / 400 / 415 three-phase									
Voltage tolerance [V]	400 ±20% @ full load ¹									
Frequency [Hz]	45 - 65									
Power factor	>0.99									
Harmonic current distortion [THDi]	<3%									
Soft start	0 - 100% in 120 s (selectable)									
BYPASS										
Rated voltage [V]	380 / 400 / 415 three-phase + N									
Frequency [Hz]	50 or 60 selectable									
Frequency tolerance	±2% (selectable from ±1% to ±5%)									
Standard equipment	Backfeed protection; separable bypass line									
OUTPUT										
Nominal power [kVA]	100	120	160	200	250	300	400	500	600	800
Active power [kW]	100	120	160	200	250	300	400	500	600	800
Number of phases	3 + N									
Rated voltage [V]	380 ¹ / 400 / 415 three-phase + N (selectable)									
Static stability	±1%									
Dynamic stability	EN 62040-3 class performance 1 non-linear load									
Voltage distortion	<1% with linear load / <3% with non-linear load									
Crest factor [I _{peak} /I _{rms}]	3:1									
Frequency stability on battery	0.05%									
Frequency [Hz]	50 or 60 (selectable)									
Overload	110% for 60 min; 125% for 10 min; 150% for 1 min									
BATTERIES										
Type	VRLA AGM/GEL/NiCd/Li-ion/SuperCaps									
Recharging method	One level, Two level, Cyclic recharge (selectable)									
Battery arrangement (parallel systems)	Separate/Common									
OVERALL SPECIFICATIONS										
Weight [kg]	850	850	1010	1065	1300	1520	1670	2500	2830	3950
Dimensions (WxDxH) [mm]	800x850x1900		1000x850x1900			1500x1000x1900		2100x1000x1900		3200x1000x1900
Remote signals	1x opto insulated Input and 3x relays Outputs									
Auxiliary signals	R.E.P.O. - External manual bypass - External output switch									
Communication	UPS status LEDs - Graphic display - 2 slots for communications interface - 2x RS232									
Ambient temperature for the UPS	0 °C - +40 °C									
Recommended temperature for battery life	+20 °C - +25 °C									
Range of relative humidity	5-95% non-condensing									
Colour	RAL 7016									
Noise level at 1 m [dBA ±2] ECO Mode	65	68				72				
IP rating	IP20									
ECO Mode efficiency	up to 99%									
Standards	European directives: LV 2014/35/EU low voltage Directive EMC 2014/30/EU electromagnetic compatibility Directive Standards: Safety IEC EN 62040-1; EMC IEC EN 62040-2; RoHS compliant Classification in accordance with IEC 62040-3 (Voltage frequency Independent) VFI - SS - 111									
Moving the UPS	Pallet jack									

¹ For wider tolerance conditions apply.



MODELS	MSB 800	MSB 1200	MSB 1600	MSB 2000	MSB 3000
OPERATING SPECIFICATIONS					
Nominal power [kVA]	800	1200	1600	2000	3000
Rated voltage [V]	380 / 400 / 415 three-phase + N				
Voltage tolerance	±15% (selectable from ± 10% to ±25%)				
Frequency [Hz]	50 / 60				
Frequency tolerance	±2% (selectable from ±1% to ±6%)				
Standard equipment provided	Backfeed protection				
Permitted overload ¹	110% for 60 min; 125% for 10 min; 150% for 1 min				
OVERALL SPECIFICATIONS					
Weight [kg]	-	800	1100	1200	2000
Weight SW ² version [kg]	570	1000	1610	-	-
Dimensions (WxDxH) [mm]	-	1400x1000x1900	2200x1000x1900	2200x1000x1900	3600x1000x1900
Dimensions SW ² version (WxDxH) [mm]	1000x1000x1900	1800x1000x1900	3000x1000x1900	-	-
Remote signals	1x opto insulated Input and 3x relays Outputs				
Auxiliary signals	R.E.P.O. - External manual bypass - External MSB output switch - External system output switch				
Communications	MSB status LEDs - Graphic display - 2 slots for communications interface - 2x RS232				
Ambient temperature for the MSB	0 °C - +40 °C				
Recommended temperature for battery life	+20 °C - +25 °C				
Range of relative humidity	5-95% non-condensing				
Colour	RAL 7016				
Noise level at 1 m [dBA ±2]	<65				
IP rating	IP20				
Standards	European directives: LV 2014/35/EU low voltage Directive EMC 2014/30/EU electromagnetic compatibility Directive Standards: Safety IEC EN 62040-1; EMC IEC EN 62040-2; RoHS compliant				
Moving the UPS	Pallet jack				

¹ Conditions apply.

² SW version includes input, output and manual bypass switches.